

T A B L E O F C O N T E N T S

- 1 FINEX, who are we?**
- 2 The FINEX products, standards and approvals.**
- 3 Projects by FINEX.**
- 4 FINEX, Technical charts and installation guides.**
 - 4.1 Balconie-Patio**
 - 4.2 Heat screen**
 - 4.3 Wall and ceiling**
 - 4.4 Foundation wall**
- 5 FINEX marketing tools.**
- 6 Warranty.**
- 7 To contact us.**

Specialist in fibercement panels since 1996 whose composition is made of cement and synthetic fibers being able to be used for any kind of residential to industrial project.

Ideal for projects asking the following characteristics:

- Can be installed in contact with ground and below grade.
- Structural panel (horizontal application over joists at 16" o/c)
- Can be used as is without further finish or protection.
- Impact and corrosion resistant.
- Fire and heat resistant, non-combustible.
- Resistant to the ultraviolet rays.
- **INTERIOR** and **EXTERIOR** use.

Panels can be painted with the **FINEX** finishing products or equivalent.

USE FOR:

EXTERIOR

BALCONY
DECK
PROTECTION OF
EXTERIOR INSULATION
WALL SIDING
GARDEN SHED
ROOF
ETC.

INTERIOR

FLOOR
WALL AND CEILING
GARAGE
BASEMENT
BATHROOM
WINE CELLAR
KITCHEN
HEAT SCREEN
STOVE BASES
ETC.

SIZES AND SURFACES AVAILABLE

SMOOTH



TEXTURED



** SEE SAMPLES AT THE END OF THE SALE PORTFOLIO.*

PANEL USE FOR:

HORIZONTAL AND VERTICAL

- 1/2" – 4' X 8' SMOOTH
- 1/2" – 4' X 8' TEXTURED
- 1/2" – 4' X 10' SMOOTH
- 1/2" – 4' X 10' TEXTURED

VERTICAL ONLY

- 1/4" – 4' X 4' SMOOTH
- 1/4" – 4' X 4' TEXTURED
- 1/4" – 4' X 8' SMOOTH
- 1/4" – 4' X 8' TEXTURED

ALWAYS APPLY THE 3 FOLLOWING POINTS:

1. Panels must be dry prior to installation.
2. Leave a minimum space of 1/8" (3 mm) between panels for expansion. If a flexible adhesive sealant is used, leave a minimum space of 1/4" (6 mm). A bond breaking tape is required to prevent the flexible sealant from adhering under the joint. Sealing of the joints is not required.
3. Pre-drill holes that are 1/16" (1.5 mm) larger than the diameter of the screws that will be used.

FINISHING PRODUCTS:



Surface cleaner:

Hydrochloric base cleaner designed to clean and prepare **FINEX** fibercement panels prior to the application of a coating.

It removes dirt, efflorescence and makes the surface porous which improves penetration and adhesion of the coating.

4 liters of concentrated product covers up to 200 sq. ft.

Screws finishing compound:

Contains:

- 1 cement polymer bag
- 1 can of liquid adhesive.

High performance two-components specially designed for finishing screw heads.

Can will cover 8 to 10 sheets

For more informations consult the label of the product.

FINISHING PRODUCTS:



Anti-Slip Acrylic:

High performance product specially designed to protect and enhance **FINEX** FIBER CEMENT PANELS.

It can be used for exterior or interior, vertical or horizontal, applications with light to medium traffic such as balconies and patios.

Available in 4 colors:
Concrete Grey, Blue Grey, Taupe, Sand.

Coverage: A 3.78 liters pail will cover up to 160 sq.ft.
(2 coats can be necessary)

**Wait 4 to 6 hours between each coat.*

Clear Sealer:

High performance product specially designed to give a wet look to **FINEX** FIBERCEMENT PANELS.

Sealer provides a hard, dust-free surface. Treated surfaces resist oil, grease, calcium and stains.

Coverage: A 3.78 liters pail will cover up to 200 sq.ft.
(2 coats are required)

**Apply a second coat once the surface is dry to the touch (+/- 2 hours).*

For more informations consult the label of the product.

PROJECTS BY FINEX



PROJECTS BY FINEX



PROJECTS BY FINEX

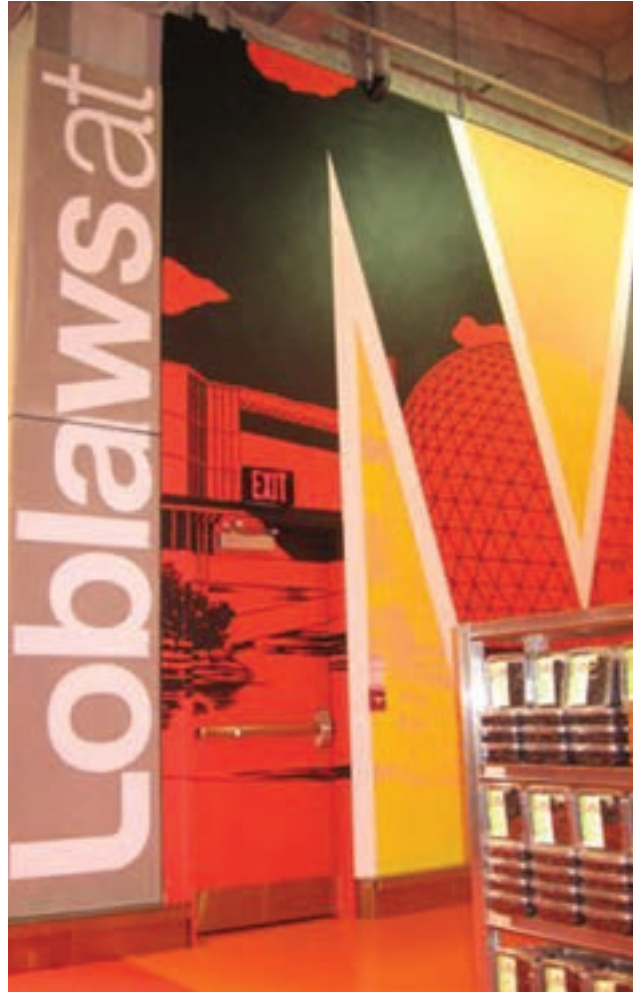

PROJECTS BY FINEX

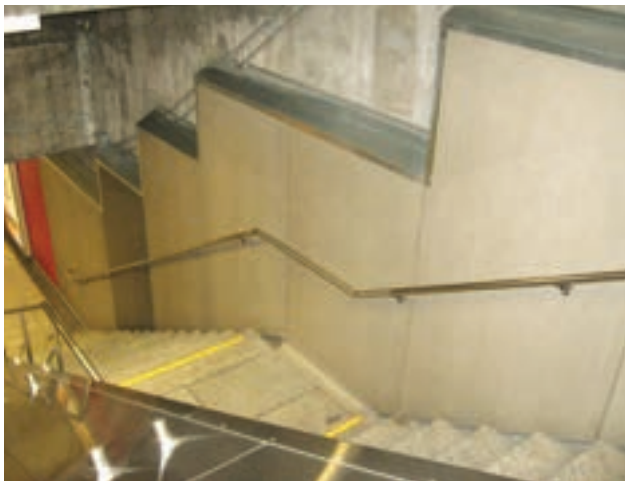

PROJECTS BY FINEX



PROJECTS BY FINEX



PROJECTS BY FINEX



PROJECTS BY FINEX



PROJECTS BY FINEX



4.1 DECKS AND BALCONIES – INSTALLATION GUIDE

Any construction should be made in accordance with Local Building Codes.

Preparation

- Provide for a slope of 1/8" per foot (10 mm per m) away from the building to facilitate water drainage.
- Minimum 2" x 6" joists (51 mm x 152 mm) must be spaced a maximum 16" (400 mm) o.c. the joists must be straight and in perfect condition.

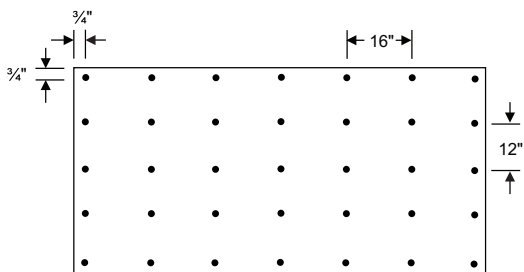

3/4" on 16" o.c. framing; fasten every 12" along the joists.

Fastening pattern

- Use 1/2" (12 mm) thick Finex panels.
- When installing Finex panels on wood joists, apply waterproofing tape (e.g. 15 lb building paper) on the joists before fastening the panels in order to prevent moisture transfer. If you are using a flexible adhesive sealant, replace the waterproofing tape with a bond-breaking tape.
- Double up the joists and use blocks (perpendicular to the joists) under all panel joints in order to provide proper support along the full perimeter of the panel, as well as under the joists, and to allow for the fastening of screws into the centre of the joists.

Installation (NEVER GLUE THE PANELS)

- Make sure that the panels are completely dry before the installation.
- In an open and well ventilated area, cut panels to size using a circular saw or a jigsaw with a concrete and masonry blade with carbide/diamond tip. It is recommended that you wear safety goggles and a NIOSH-approved dust mask for crystalline silica.
- Countersink 1/8" (3 mm) holes into the panel. Use a bit to pre-drill holes that are 1/16" (1,5 mm) larger than the diameter of the screws that will be used. Fasten the panel 3/4" (19 mm) from the edge every 12" (305 mm) along the joists. Stainless steel screws are recommended.

Expansion joints

- **NOTE:** The flexible adhesive sealant manufacturer's instructions take precedence over the following.
- Leave a space of at least 1/2" (12 mm) along the width of the panels and 1/4" (6 mm) along the length.
- Install bond-breaking tape (over the joist) to prevent the flexible sealant from adhering under the joint.
- Install masking tape on each side of the joint to gather any excess sealant.
- Ensure that the panel edges are clean and dry. Remove any dust with a brush and a dry cloth before the application of the flexible adhesive sealant.
- Fill joints with a paintable adhesive sealant that will remain flexible. A polyurethane base sealant is recommended.
- Do not apply the flexible adhesive sealant under direct sunlight or if the temperature is below 4° C.
- Allow 5 to 7 days for sealant to cure prior to painting or cleaning the surface.
- **NOTE:** The installation of Finex panels with adhesive sealant or finishing products should not be considered as a waterproofing system. If such a system is required, put it in place before you install the Finex panels or after with a fluid-applied waterproofing system.

ALWAYS APPLY THE 3 FOLLOWING POINTS:

1. Panels must be dry prior to installation.
2. Leave a minimum space of 1/8" (3 mm) between panels for expansion. If a flexible adhesive sealant is used, leave a minimum space of 1/4" (6 mm). A bond breaking tape is required to prevent the flexible sealant from adhering under the joint. Sealing of the joints is not required.
3. Pre-drill holes that are 1/16" (1.5 mm) larger than the diameter of the screws that will be used.

STEP BY STEP

Joists spaced 16" (400 mm) o.c. Use double joists and perpendicular blocks under joints.



1 Installation on bond-breaking tape



2 Drilling



3 Countersinking



4 Hole must be larger than diameter of screw



5 Leave a space



6 Installation of masking tape



7 Application of flexible adhesive sealant

4.2 HEAT SCREEN – INSTALLATION GUIDE

Any construction should be made in accordance with Local Building Codes.

Preparation

Walls must be flat, uniform, dry and free of dirt, dust and grease.

Installation

Use 1/2" (12 mm) panels for stove bases and 1/4" (6 mm) panels for heat screens. Panels must extend a minimum of 12" (300 mm) on each side of the appliance. On vertical metal furring strips (or FINEX panel strips) fastened and aligned on the studs, put the heat shield on the wall. Leave a minimum 1" (24 mm) space between the heat shield and the wall to ensure proper air circulation. The screws must be long enough to penetrate at least 3/4" (19 mm) into the framing. Leave a minimum gap of 1" (24 mm) above the panel and 3" (72 mm) below the panel.

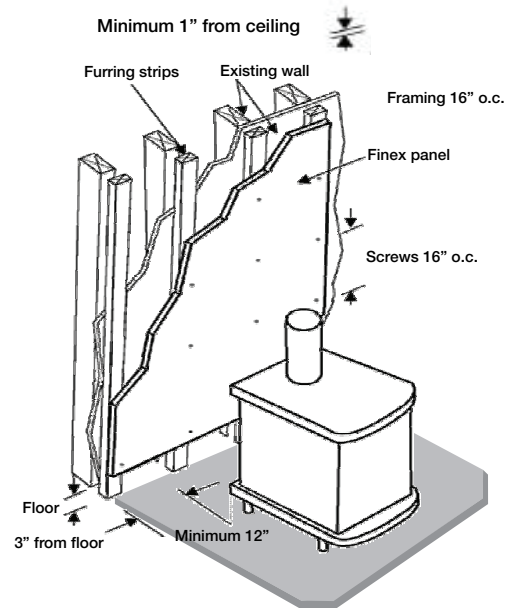

Fastening

Drill holes using a bit with a diameter that is 1/16" (1,5 mm) larger than the diameter of the screws. Fasten the FINEX panels onto the furring 16" (400 mm) o.c., 3/4" (19 mm) minimum from the edge of the panels. At corners of panels, place fasteners in an asymmetric position at a minimum of 2" from corner and 1" from the edge.

NOTE: Follow the manufacturer's instructions to determine the distance between the screen and the appliance. That distance may be reduced by 2/3 with a FINEX heat screen. FINEX panel can be used as a stove base. Use a high temperature paint for finishing.

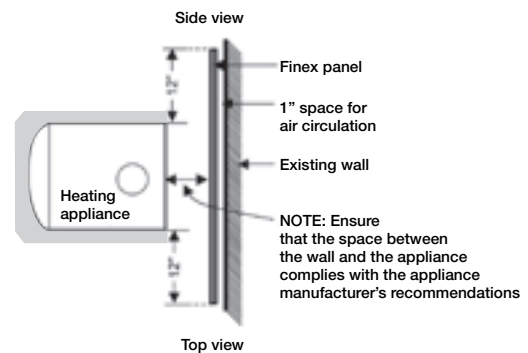

WARNING: Do not locate any screws directly behind the appliance. Do not glue stone, ceramic, brick or any decorative covering on FINEX panels when they are used as a heat screen.

NOTE: Do not countersink screw head with 1/4" (6 mm) panel.

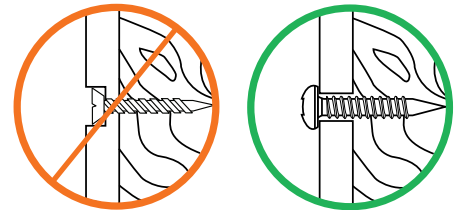

ALWAYS APPLY THE 3 FOLLOWING POINTS:

1. Panels must be dry prior to installation.
2. Leave a minimum space of 1/8" (3 mm) between panels for expansion. If a flexible adhesive sealant is used, leave a minimum space of 1/4" (6 mm). A bond breaking tape is required to prevent the flexible sealant from adhering under the joint. Sealing of the joints is not required.
3. Pre-drill holes that are 1/16" (1.5 mm) larger than the diameter of the screws that will be used.

4.3 WALLS AND CEILINGS – INSTALLATION GUIDE

Any construction should be made in accordance with Local Building Codes.

Preparation

Walls and ceilings must be flat, uniform, dry and free of dirt, dust and grease.

Walls

- Studs and fasteners must be spaced a maximum of 16" (400 mm) o.c. in areas where the humidity is very high and 24" (600 mm) elsewhere.
- Use 1/2" (12 mm) panels for walls where the risk of impact is high.
- Locate joints on centre of studs or joists or furring strips. Leave a minimum space of 1/8" (3 mm) between panels for expansion. If a flexible adhesive sealant is used, leave a minimum space of 1/4" (6 mm). A polyurethane base sealant is recommended. (see note #2 below).
- Pre-drill holes that are 1/16" (1,5 mm) larger than the diameter of the screws that will be used. Fasteners must penetrate at least 3/4" (19 mm) into a solid substrate (wood or metal stud).
- Avoid aligning panel joints with door or window openings in order to prevent cracks due to shifting of the framing.
- Fasteners must be placed 3/4" (19 mm) minimum from the edges of the panels.
- At corners of panels, place fasteners in an asymmetric position at a minimum of 2" from corner and 1" from the edge.

Ceilings

- Joists, rafters and fasteners must be spaced a maximum of 24" (600 mm) o.c.
- Fasten panels perpendicular to joists in order to ensure that stress is distributed crosswise.
- Locate joints on centre of studs or joists or furring strips. Leave a minimum space of 1/8" (3 mm) between panels for expansion. If a flexible adhesive sealant is used, leave a minimum space of 1/4" (6 mm). A polyurethane base sealant is recommended. (see note #2 below).
- Pre-drill holes that are 1/16" (1,5 mm) larger than the diameter of the screws that will be used. Fasteners must penetrate at least 3/4" (19 mm) into a solid substrate (wood or metal stud).
- Fasteners must be placed 3/4" (19 mm) minimum from the edges of the panels.
- At corners of panels, place fasteners in an asymmetric position at a minimum of 2" from corner and 1" from the edge.

Fasteners in an asymmetric position at the corners of panels

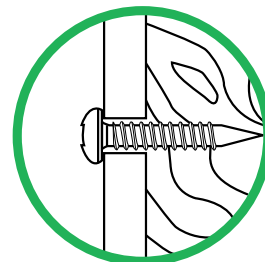
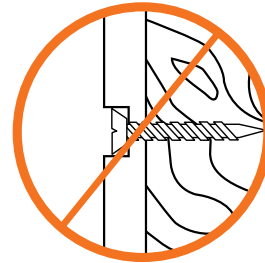
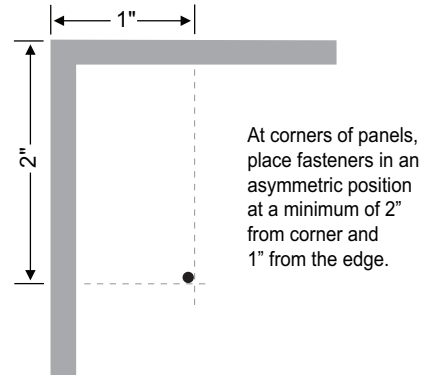

NOTE: Do not countersink screw head with 1/4" (6 mm) panel.

ALWAYS APPLY THE 3 FOLLOWING POINTS:

1. Panels must be dry prior to installation.
2. Leave a minimum space of 1/8" (3 mm) between panels for expansion. If a flexible adhesive sealant is used, leave a minimum space of 1/4" (6 mm). A bond breaking tape is required to prevent the flexible sealant from adhering under the joint. Sealing of the joints is not required.
3. Pre-drill holes that are 1/16" (1.5 mm) larger than the diameter of the screws that will be used.

4.4 FOUNDATION – INSTALLATION GUIDE

Any construction should be made in accordance with Local Building Codes.

Cut FINEX panels to maximum 4' (1,22 m) lengths

- Install panels 12" (300 mm) below ground level and fasten every 24" (600 mm) along the width and height of the panels.
- Drill holes using a bit with a diameter that is 1/16" (1,5 mm) larger than the diameter of the screws. Fasteners must penetrate at least 3/4" (19 mm) into the concrete or furring strips.
- Fasteners must be placed 3/4" (19 mm) minimum from the edges of the panels.
- At corners of panels, place fasteners in an asymmetric position at a minimum of 2" from corner and 1" from the edge.
- Leave a minimum space of 1/8" (3 mm) between panels for expansion. If a flexible adhesive sealant is used, leave a minimum space of 1/4" (6 mm). A bond breaking tape is required to prevent the flexible sealant from adhering under the joint. Sealing of the joints is not required.
- The use of flashing is recommended to cover the screws on the top part of the panels. Use backfill to cover all other screws.

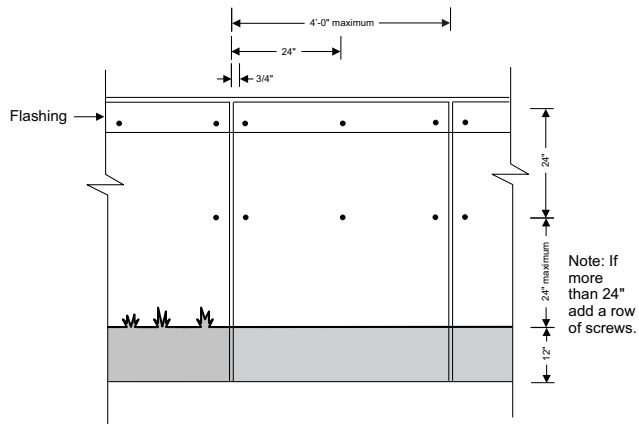
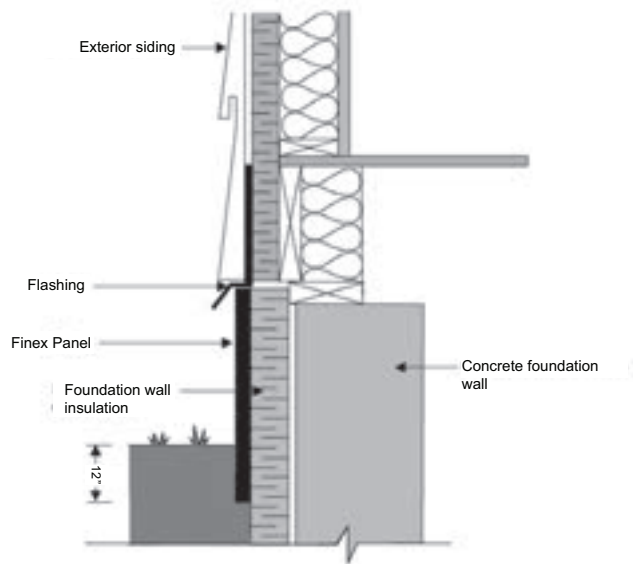

Fasteners in an asymmetric position at the corners of panels

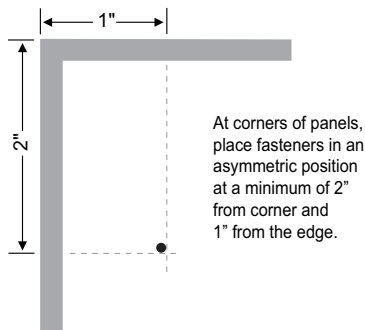



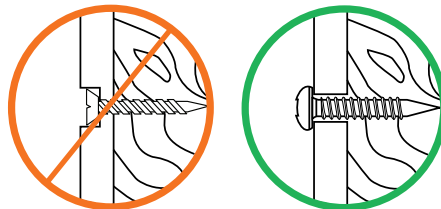







NOTE: Do not countersink screw head with 1/4" (6 mm) panel.



ALWAYS APPLY THE 3 FOLLOWING POINTS:

1. Panels must be dry prior to installation.
2. Leave a minimum space of 1/8" (3 mm) between panels for expansion. If a flexible adhesive sealant is used, leave a minimum space of 1/4" (6 mm). A bond breaking tape is required to prevent the flexible sealant from adhering under the joint. Sealing of the joints is not required.
3. Pre-drill holes that are 1/16" (1.5 mm) larger than the diameter of the screws that will be used.

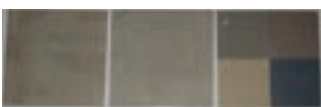
SALES SUPPORT PROGRAM

PICTURES	DESCRIPTION	DIMENSION	PRICE	QTY ORDER
	DISPLAY Also include a heat screen & stove base interchangeable heading	2' X 4' X 4'	NO CHARGE (VALUE OF \$ 250.00)	
	DISPLAY	16" X 16" X 60"	NO CHARGE (VALUE OF \$ 175.00)	
	INSTALLATION GUIDE	8.5" X 11"	NO CHARGE	
	TEARPAD FINISHING PRODUCT	8.5" X 11"	NO CHARGE	
	TEARPAD HEAT SCREEN & STOVE BASE	8.5" X 11"	NO CHARGE	
	TEARPAD DECKS & BALCONIES	8.5" X 11"	NO CHARGE	
	TEARPAD PROTECTION OF EXTERIOR INSULATION	8.5" X 11"	NO CHARGE	
	SALES BINDER	8.5" X 11"	NO CHARGE (VALUE OF \$ 35.00)	
	SAMPLES (8" X 8")	Thickness of 1/4" & 1/2"	NO CHARGE	
	1) Smooth			
	2) Textured			
	3) 4 colours with Clear Sealer			
	SIKAFLEX CAULKING	2" X 4"	NO CHARGE	
SHIP TO:	Distributed by: 			
PHONE:				
CONTACT :				

LIMITED LIFETIME WARRANTY

1. Under the terms of this warranty, **FINEX** warrants the product against manufacturing default, delamination, rot, deterioration due to ultraviolet rays, corrosion. This warranty does not cover any other damages. **FINEX** reserves the right to void all warranties if the installation requirements are not respected. The requirements are found in the **FINEX** installation guide and Website (www.gofinex.com). The purchaser recognizes that the product is subject to naturally occurring variations (contraction/expansion, texture, minor dimensional differences). **FINEX** reserves the right to inspect the product prior to any repairs, and to confirm that the product displays the defect covered by this warranty.
2. **FINEX** sole responsibility is to replace the product damaged by manufacturing default, delamination, rot, deterioration due to ultraviolet rays, corrosion and specifically excludes all other damage, of whatever nature, excluding any cost of labour, installation or reinstallation costs and other direct or indirect damage, real or anticipated, present or future.
3. Any product found to be unsatisfactory prior to installation, for any reason, must not be installed. The warrantor will not be responsible, in any way, for labour or material if a defective or non-standard product is installed. The warrantor shall not be liable for any consequential or special damages, or for other expenses (sheathing, fasteners, caulking, etc.) which may arise in connection with this warranty.
4. In purchasing the product, the purchaser accepts the terms and conditions of this warranty, which replaces any other representation, warranty or condition, explicit or implicit, statutory or other.
5. This warranty is automatically transferable to the subsequent purchaser of the residential or commercial building upon which the product has been installed. Any claim under this warranty by the purchaser or subsequent owner, as the case may be, must be made in writing during the period covered by the warranty and must include the original invoice for the product. The quantity of replacement product will correspond to the quantity of product affected.



TEL.: 450-373-0909
 1-877-923-4639
 FAX: 450-377-0440
 info@gofinex.com
 www.gofinex.com

MULTI-PURPOSE FIBER CEMENT PANELS

CLAIM FORM PLEASE SEND PICTURES BY E-MAIL TO: info@gofinex.com

Date of Claim	
Name of Consumer	
Address	
Phone	

Retailer	
Address	
Contact	
Phone	

QTY & PRODUCTS:

1/4" X 4' X 4' Panel	Smooth		1/2" X 4' X 8' Panel	Smooth	
	Textured			Textured	
1/4" X 4' X 8' Panel	Smooth		1/2" X 4' X 10' Panel	Smooth	
	Textured			Textured	

Finishing Products		
Date of Purchase		Invoice #

PROBLEM DESCRIPTION:

POINTS TO VERIFY	YES	NO	COMMENTS
Frame: Straight and flat			
Slope of 1/8" per foot			
Joist at 16" o/c or less			
Holes pre-drilled 1/16" larger than screw diameter			
Double joists on joints panels (screw min 3/4" from edge of panel)			
Expansion joint of 1/8" or more			
Fastening pattern respected			
Surface was cleaned prior to paint application			
Painted surface			
Sealed surface			
Flexible caulking for joints			
Production date (edge of the panel)			
Installation date			

COMMENTS:

RECOMMENDATION / SOLUTION:

FINEX REPRESENTATIVE:

TO CONTACT US

FINEX SYSTEMS INC.

24 St-Louis, suite 130

Salaberry-de-Valleyfield, Quebec, Canada J6T 1M4

Tel.: 450-373-0909 or 1-877-923-4639

Fax: 450-377-0440

E-mail: info@gofinex.com

www.gofinex.com

DISTRIBUTOR

DOMAN[™]
BUILDING MATERIALS